



pro audio



# ES series ES104

## Two-way Loudspeaker System

The **ES104** is a highly weather-resistant, single 4" 2-way full range outdoor loudspeaker, the body is made of engineering plastic injection molding. fitted with one 4" mid-woofer and one 0.8" dome tweeter. The system conforms to IP65 international standard. ES104T is equipped with multi-tap transformer based on ES104.

ES104是一款4"两分音系列音箱。箱体设计优先考虑全天候使用环境，采用工程塑胶注塑而成，一只4寸中低音单元和一只20芯球顶高音配置。带T的产品配置多种输出功率选择功能的定压音箱。产品符合IP65国际标准。

### FEATURES

- Highly weather-resistant IP65 rating
- Engineering plastic injection molding
- Two kinds of mounting brackets
- Good used for meeting rooms, shops, water parks, outdoor background music, swimming pools, and a wide variety of other outdoor or indoor background music

### 产品特点

- 采用工程塑胶注塑而成

### 适用范围

- 用于分散扩声
- 会议室
- 主题公园、景区扩声

### CONFIGURATION

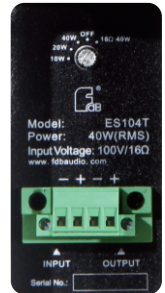
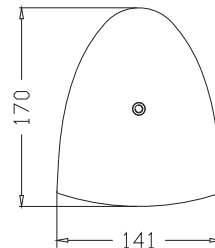
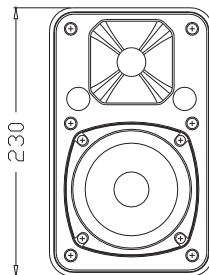

#### MODEL

FREQUENCY RESPONSE(-3dB)

FREQUENCY RESPONSE(-10dB)

DRIVERS

INPUT VOLTAGE

RATED POWER

SENSITIVITY

MAXIMUM SPL

IMPEDANCE

DISPERSION(-6dB)

CROSSOVER FREQUENCIES

INPUT CONNECTORS

PACKAGE SIZE

NET WEIGHT

GROSS WEIGHT

#### ES104B/ES104W

75Hz-20kHz

70Hz-20kHz

1×4"(100mm)/1"voice coil LF

1×0.8"(20mm)/dome tweeter

40W RMS,160W peak

88dB 1watt/1 metre

104dB continuous,110dB peak

16 ohms nominal

120°×90°

3.5kHz passive

covered barrier strip terminals

414mm×190mm×285mm(1Pair)

2 kg/pc

6 kg/pair

#### ES104BT/ES104WT

75Hz-20kHz

70Hz-20kHz

1×4"(100mm)/1"voice coil LF

1×0.8"(20mm)/dome tweeter

100V

10W/20W/40W/OFF/16Ω

88dB 1watt/1 metre

104dB continuous,110dB peak

16 ohms nominal

120°×90°

3.5kHz passive

covered barrier strip terminals

414mm×190mm×285mm(1Pair)

3 kg/pc

7 kg/pair

# ES series ES106

## Two-way Loudspeaker System



The **ES106** is a highly weather-resistant, single 6" 2-way full range outdoor loudspeaker, the body is made of engineering plastic injection molding, fitted with one 6" mid-woofer and one 1" HF driver. The system conforms to IP65 international standard. ES106T is equipped with multi-tap transformer based on ES106.

ES106是一款6"两分音系列音箱。箱体设计优先考虑全天候使用环境，采用工程塑胶注塑而成，一只6寸中低音单元和一只25芯高音驱动器。带T的产品配置多种输出功率选择功能的定压音箱。产品符合IP65国际标准。

### CONFIGURATION

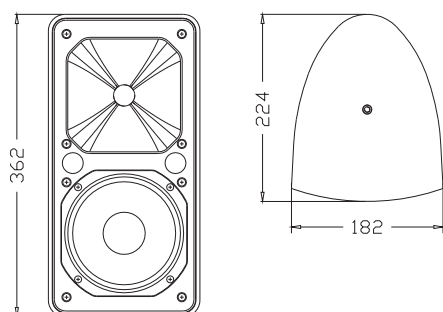

### FEATURES

- Highly weather-resistant IP65 rating
- Engineering plastic injection molding
- Two kinds of mounting brackets
- Good used for meeting rooms, shops, water parks, outdoor background music, swimming pools, and a wide variety of other outdoor or indoor background music

### 产品特点

- 采用工程塑胶注塑而成

### 适用范围

- 用会议室多功能厅
- 主题公园、景区扩声

#### MODEL

FREQUENCY RESPONSE(-3dB)

FREQUENCY RESPONSE(-10dB)

DRIVERS

INPUT VOLTAGE

RATED POWER

SENSITIVITY

MAXIMUM SPL

IMPEDANCE

DISPERSION(-6dB)

CROSSOVER FREQUENCIES

INPUT CONNECTORS

PACKAGE SIZE

NET WEIGHT

GROSS WEIGHT

#### ES106B/ES106W

60Hz-18kHz

55Hz-20kHz

1×6"(150mm)/1.5"voice coil LF

1×1"(25mm)/1"voice coil HF

80W RMS,320W peak

89dB 1watt/1 metre

108dB continuous,114dB peak

16 ohms nominal

90°×60°

2.4kHz passive

covered barrier strip terminals

528mm×222mm×407mm(1 pair)

5 kg/pc

15 kg/pair

#### ES106BT/ES106WT

60Hz-18kHz

55Hz-20kHz

1×6"(150mm)/1.5"voice coil LF

1×1"(25mm)/1"voice coil HF

100V

20W/40W/80W/OFF/16Ω

89dB 1watt/1 metre

108dB continuous,114dB peak

16 ohms nominal

90°×60°

2.4kHz passive

covered barrier strip terminals

528mm×222mm×407mm(1 pair)

6 kg/pc

16 kg/pair



pro audio



# ES series ES108

## Two-way Loudspeaker System

The ES108 is a highly weather-resistant, single 8" 2-way full range outdoor loudspeaker, the body is made of engineering plastic injection molding, fitted with one 8" mid-woofer and one 1" HF driver. The system conforms to IP65 international standard. ES108T is equipped with multi-tap transformer based on ES108.

ES108是一款8"两分音系列音箱。箱体设计优先考虑全天候使用环境，采用工程塑胶注塑而成，一只8寸中低音单元和一只25芯高音驱动器。带T的产品配置多种输出功率选择功能的定压音箱。产品符合IP65国际标准。

### FEATURES

- Highly weather-resistant IP65 rating
- Engineering plastic injection molding
- Two kinds of mounting brackets
- Good used for meeting rooms, shops, water parks, outdoor background music, swimming pools, and a wide variety of other outdoor or indoor background music

### 产品特点

- 采用工程塑胶注塑而成

### 适用范围

- 用会议室多功能厅
- 主题公园、景区扩声

### CONFIGURATION

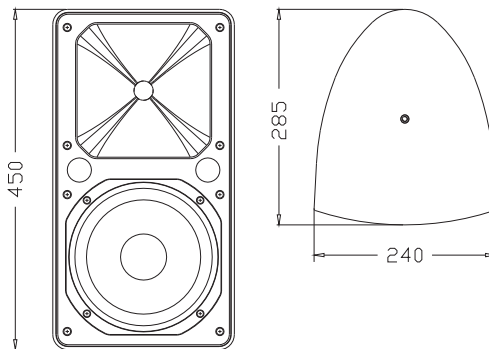

#### MODEL

FREQUENCY RESPONSE(-3dB)

FREQUENCY RESPONSE(-10dB)

DRIVERS

INPUT VOLTAGE

RATED POWER

SENSITIVITY

MAXIMUM SPL

IMPEDANCE

DISPERSION(-6dB)

CROSSOVER FREQUENCIES

INPUT CONNECTORS

PACKAGE SIZE

NET WEIGHT

GROSS WEIGHT

#### ES108B/ES108W

60Hz-18kHz

55Hz-20kHz

1×8"(200mm)/2"voice coil LF

1×1"(25mm)/1"voice coil HF

150W RMS,600W peak

94dB 1watt/1 metre

116dB continuous,122dB peak

16 ohms nominal

90°×50°

2.3kHz passive

covered barrier strip terminals

352mm×292mm×495mm

9 kg/pc

11 kg/pc

#### ES108BT/ES108WT

60Hz-18kHz

55Hz-20kHz

1×8"(200mm)/2"voice coil LF

1×1"(25mm)/1"voice coil HF

100V

37.5W/75W/150W/OFF/16Ω

94dB 1watt/1 metre

116dB continuous,122dB peak

16 ohms nominal

90°×50°

2.3kHz passive

covered barrier strip terminals

352mm×292mm×495mm

10 kg/pc

12 kg/pc